

## MDT 389 L12

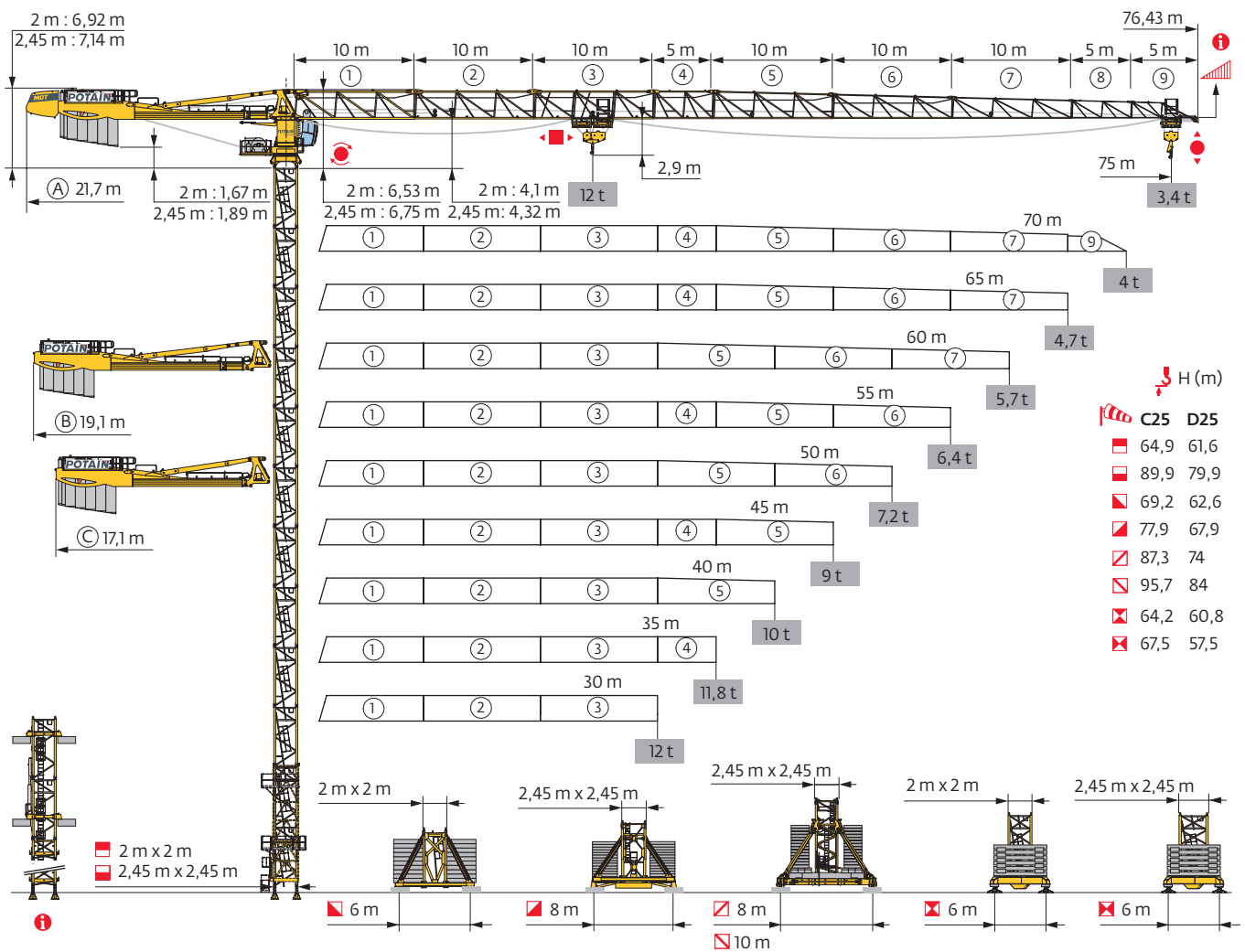

Potain Plus



Power Control

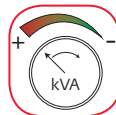

CraneSTAR



Top Site

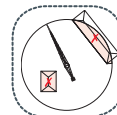

Top Tracing 3

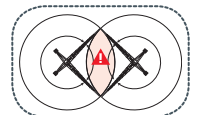

Mât - Réactions / Mast - Reaktionskräfte / Mast - Reactions / Mástil - Reacciones / Torre - Reazioni  
Tramo - Reacções / Реакция опор мачты

**2 m - P 62B - C25**

AVAIL (m)	30	35	40	45	50	55	60	65	70	75
$\downarrow$ (m)	63,2	64,9	64,9	63,2	64,9	64,9	64,9	61,6	61,6	61,6
$\downarrow/P_+$ (m)	63,2	59,9	61,6	61,6	64,9	61,6	64,9	61,6	61,6	61,6
3,33 m	2	1	1	2	1	1	1	0	0	0
	5 m	11	12	12	11	12	12	12	12	12
F2 (t)	● 188	199	198	192	203	197	196	199	201	203
	■ 255	273	273	256	278	279	282	253	262	270
F3 (t)	● 127	135	133	127	135	130	130	132	133	135
	■ 201	216	215	197	216	217	221	192	201	208
$\downarrow$ (m) D25	61,6	61,6	61,6	61,6	59,9	59,9	59,9	59,9	58,2	58,2
$\downarrow/P_+$ (m) D25	61,6	59,9	61,6	61,6	59,9	59,9	59,9	59,9	58,2	58,2

**2 m - V 60A - V 63A - C25**

AVAIL (m)	30	35	40	45	50	55	60	65	70	75
$\downarrow$ (m)	65,9	65,9	65,9	65,9	65,9	65,9	64,2	62,5	62,5	62,5
$\downarrow/P_+$ (m)	65,9	60,9	60,9	60,9	65,9	60,9	64,2	62,5	62,5	62,5
3,33 m	0	0	0	0	0	0	1	2	2	2
	5 m	12	12	12	12	12	11	10	10	10
F1 (t)	● 111	114	114	111	117	115	110	112	113	114
	■ 138	140	140	137	142	142	137	129	135	139
$\downarrow$ (m) D25	57,5	57,5	57,5	59,2	57,5	57,5	57,5	57,5	55,9	55,9
$\downarrow/P_+$ (m) D25	57,5	57,5	57,5	59,2	57,5	57,5	57,5	57,5	55,9	55,9

**2 m - V 63A - C25**

AVAIL (m)	30	35	40	45	50	55	60	65	70	75
$\downarrow$ (m)	69,2	65,9	67,6	69,2	69,2	69,2	69,2	65,9	65,9	65,9
$\downarrow/P_+$ (m)	69,2	60,9	60,9	60,9	65,9	60,9	69,2	65,9	65,9	65,9
3,33 m	1	0	2	1	1	1	1	0	0	0
	5 m	11	11	10	11	11	11	11	11	11
F1 (t)	● 124	115	119	124	125	125	124	122	123	127
	■ 160	144	153	159	163	164	166	152	158	163
$\downarrow$ (m) D25	60,9	60,9	60,9	62,6	60,9	60,9	60,9	60,9	60,9	60,9
$\downarrow/P_+$ (m) D25	60,9	60,9	60,9	60,9	60,9	60,9	60,9	60,9	60,9	60,9

**2 m - ZX 6830 - C25**

AVAIL (m)	30	35	40	45	50	55	60	65	70	75
$\downarrow$ (m)	62,5	64,2	64,2	62,5	62,5	64,2	62,5	59,2	59,2	59,2
$\downarrow/P_+$ (m)	62,5	59,2	60,8	62,5	62,5	62,5	62,5	59,2	59,2	59,2
3,33 m	0	2	2	0	0	2	0	2	2	2
	5 m	12	11	11	12	12	11	12	10	10
F1 (t)	● 106	109	108	111	109	109	105	106	106	107
	■ 117	132	131	116	120	134	123	113	118	123
$\downarrow$ (m) D25	60,8	60,8	60,8	60,8	59,2	59,2	59,2	59,2	57,5	57,5
$\downarrow/P_+$ (m) D25	60,8	59,2	60,8	60,8	59,2	59,2	59,2	59,2	57,5	57,5

**2,45 m - P 800B - C25**

AVAIL (m)	30	35	40	45	50	55	60	65	70	75
$\downarrow$ (m)	74,9	74,9	74,9	76,6	74,9	74,9	74,9	73,2	71,6	71,6
$\downarrow/P_+$ (m)	74,9	74,9	74,9	76,6	74,9	74,9	74,9	73,2	71,6	71,6
3,33 m	1	1	1	0	1	1	1	2	0	0
	5 m	14	14	14	15	14	14	14	13	14
F2 (t)	● 195	205	204	207	202	203	198	204	200	202
	■ 355	359	359	370	363	364	367	361	344	350
F3 (t)	● 124	133	130	132	126	127	122	127	124	125
	■ 290	292	292	300	293	294	296	289	274	280
$\downarrow$ (m) D25	66,6	66,6	66,6	66,6	66,6	66,6	66,6	64,9	64,9	63,2
$\downarrow/P_+$ (m) D25	66,6	66,6	66,6	66,6	66,6	66,6	66,6	64,9	64,9	63,2

**2,45 m - P 850A - C25**

AVAIL (m)	30	35	40	45	50	55	60	65	70	75
$\downarrow$ (m)	89,9	88,2	89,9	89,9	88,2	88,2	88,2	88,2	86,6	86,6
$\downarrow/P_+$ (m)	89,9	88,2	89,9	89,9	88,2	88,2	88,2	88,2	86,6	86,6
3,33 m	1	2	1	1	2	2	2	2	0	0
	5 m	17	16	17	17	16	16	16	16	17
F2 (t)	● 244	248	252	252	245	246	242	254	249	250
	■ 541	522	546	544	525	527	532	539	515	522
F3 (t)	● 163	167	168	166	161	161	157	167	164	165
	■ 467	446	468	464	447	448	452	458	436	442
$\downarrow$ (m) D25	79,9	79,9	79,9	79,9	78,2	78,2	78,2	78,2	76,6	76,6
$\downarrow/P_+$ (m) D25	79,9	79,9	79,9	79,9	78,2	78,2	78,2	78,2	76,6	76,6

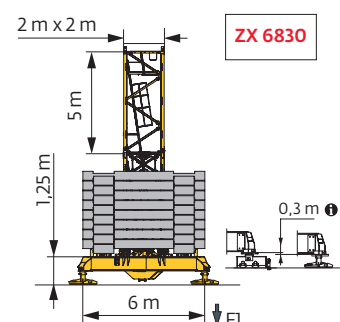
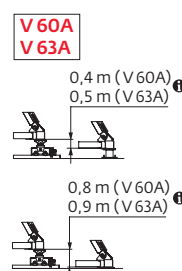
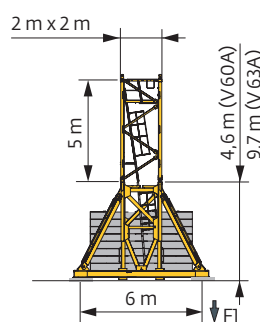
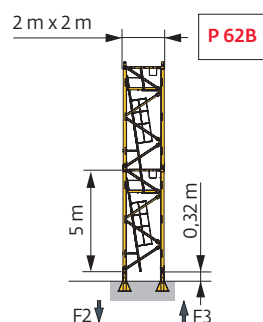

**2,45 m - Y 800B - C25**

ΔΔΔΔ (m)	30	35	40	45	50	55	60	65	70	75
↕ (m)	77,9	77,9	77,9	77,9	77,9	77,9	77,9	76,2	74,5	74,5
↕/P+ (m)	77,9	77,9	77,9	77,9	77,9	77,9	77,9	76,2	74,5	74,5
	3,33 m	0	0	0	0	0	0	1	2	2
	5 m	14	14	14	14	14	14	13	12	12
FI (t)	● 126	129	129	127	130	130	129	128	128	128
	■ 185	187	186	184	188	188	190	186	184	187
↕ (m) D25	67,9	67,9	67,9	67,9	67,9	67,9	67,9	67,9	67,9	66,2
↕/P+ (m) D25	67,9	67,9	67,9	67,9	67,9	67,9	67,9	67,9	67,9	66,2

**2,45 m - YM 850 - C25**

ΔΔΔΔ (m)	30	35	40	45	50	55	60	65	70	75
↕ (m)	85,7	85,7	85,7	87,3	85,7	85,7	85,7	85,7	85,7	85,7
↕/P+ (m)	85,7	85,7	85,7	87,3	85,7	85,7	85,7	85,7	85,7	85,7
	3,33 m	0	0	0	2	0	0	0	0	0
	5 m	15	15	15	14	15	15	15	15	15
FI (t)	● 152	156	153	159	153	153	152	156	160	160
	■ 233	235	235	247	236	237	238	242	246	249
↕ (m) D25	72,3	72,3	72,3	74	74	74	72,3	72,3	72,3	70,7
↕/P+ (m) D25	72,3	72,3	72,3	74	74	74	72,3	72,3	72,3	70,7

**2,45 m - JM 850 - C25**

ΔΔΔΔ (m)	30	35	40	45	50	55	60	65	70	75
↕ (m)	95,7	94	94	94	94	94	92,3	92,3	90,7	90,7
↕/P+ (m)	95,7	94	94	94	94	94	92,3	92,3	90,7	90,7
	3,33 m	0	1	1	1	1	2	2	0	0
	5 m	17	16	16	16	16	15	15	16	16
FI (t)	● 148	147	147	145	148	148	143	146	141	145
	■ 240	234	234	232	235	236	230	233	224	227
↕ (m) D25	84	82,3	82,3	84	82,3	82,3	82,3	82,3	82,3	80,7
↕/P+ (m) D25	84	82,3	82,3	84	82,3	82,3	82,3	82,3	82,3	80,7

**2,45 m - ZX 6830 - C25**

ΔΔΔΔ (m)	30	35	40	45	50	55	60	65	70	75
↕ (m)	67,5	65,8	65,8	67,5	65,8	65,8	65,8	64,2	62,5	62,5
↕/P+ (m)	67,5	65,8	65,8	67,5	65,8	65,8	65,8	64,2	62,5	62,5
	3,33 m	0	1	1	0	1	1	2	0	0
	5 m	13	12	12	13	12	12	11	12	12
FI (t)	● 130	129	129	133	128	129	127	129	122	123
	■ 175	169	168	174	170	171	173	170	157	161
↕ (m) D25	57,5	57,5	57,5	57,5	57,5	57,5	57,5	55,8	55,8	54,2
↕/P+ (m) D25	57,5	57,5	57,5	57,5	57,5	57,5	57,5	55,8	55,8	54,2

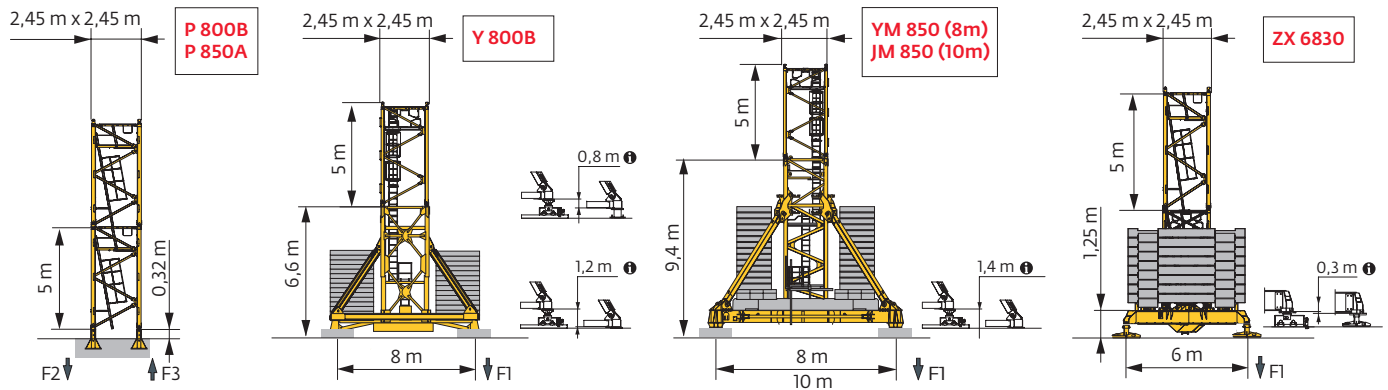

Ancrages / Verankerungen / Anchorages / Anclajes / Ancoraggi  
 Ancoragem / нкера

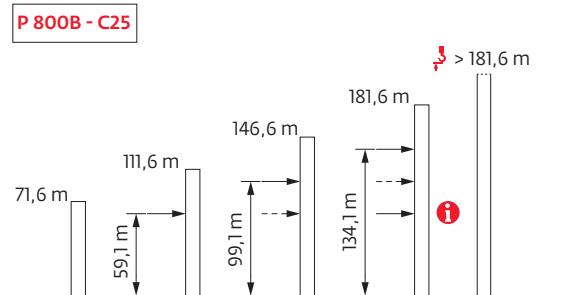
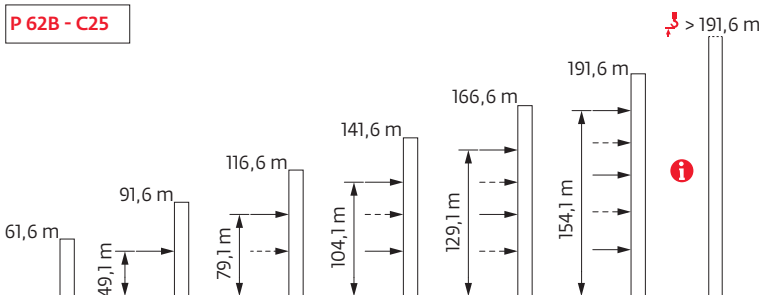

Lest de base / Grundballast / Base ballast / Lastre de base / Zavorra di base  
 Lastro da base / Базовый Балласт

⚖️(t) / 📏2 m - V60A - 🚛 - C25										
ΔVAL (m)	30	35	40	45	50	55	60	65	70	75
65,9	120	120	120	108	120	120				
64,2	120	108	108	108	108	108	108			
62,5	108	108	108	108	96	96	96	108	108	108
57,5	96	96	96	96	84	96	84	96	96	96
52,5	84	96	96	96	84	84	72	84	72	72
47,5	72	96	84	84	72	84	60	60	60	60
42,5	60	84	84	84	72	72	48	48	48	60
37,5	60	84	84	84	72	72	48	48	48	48
32,5	60	84	84	84	72	72	48	48	48	48

⚖️(t) / 📏2 m - V63A - 🚛 - C25										
ΔVAL (m)	30	35	40	45	50	55	60	65	70	75
69,2	156			144	144	144	144			
67,6	144		132	132	132	132	144			
65,9	132	120	120	120	120	120	132	132	132	144
60,9	108	108	108	96	96	96	96	108	108	108
55,9	96	96	96	96	84	84	84	96	84	84
50,9	84	96	96	84	72	84	72	72	72	72
45,9	60	84	84	84	72	72	48	60	60	60
40,9	48	84	84	84	60	72	48	48	48	60
35,9	48	84	84	84	60	72	48	48	48	48

⚖️(t) / 📏2 m - ZX 6830 - 🚛 - C25										
ΔVAL (m)	30	35	40	45	50	55	60	65	70	75
64,2		101	101			101				
62,5	111	101	101	101	101	91	91			
59,2	101	101	91	91	91	91	81	91	91	91
54,2	81	91	91	91	81	81	71	81	81	81
49,2	71	91	81	81	71	81	61	61	61	61
44,2	51	81	81	81	61	71	51	51	51	51
39,2	51	81	81	81	61	71	51	51	41	51

⚖️(t) / 📏2,45 m - Y 800B - 🚛 - C25										
ΔVAL (m)	30	35	40	45	50	55	60	65	70	75
77,9	156	156	156	144	156	156	156			
76,2	144	144	144	132	144	144	144	144		
74,5	132	132	132	132	132	132	132	132	144	144
69,5	108	108	96	96	96	96	96	96	108	108
64,5	72	72	72	60	72	72	72	72	72	84
59,5	36	36	36	36	36	36	36	36	48	48
54,5	24	24	24	24	24	12	12	24	24	24
49,5	12	24	12	12	12	12	12	12	12	12
44,5	12	24	12	12	12	12	12	12	12	12
39,5	12	24	12	12	12	12	12	12	12	12
34,5	12	24	12	12	12	12	12	12	12	12

⚖️(t) / 📏2,45 m - YM 850 - 🚛 - C25										
ΔVAL (m)	30	35	40	45	50	55	60	65	70	75
87,3				216						
85,7	216	216	204	204	204	204	204	204	216	216
80,7	168	168	168	168	168	168	168	168	180	180
75,7	132	132	132	132	132	132	132	132	144	144
70,7	96	96	96	96	96	96	96	96	108	108
65,7	72	72	72	60	60	60	72	72	72	84
60,7	48	48	48	48	48	48	48	48	48	48
55,7	48	48	48	48	48	48	48	48	48	48
50,7	48	48	48	48	48	48	48	48	48	48
45,7	48	48	48	48	48	48	48	48	48	48
40,7	48	48	48	48	48	48	48	48	48	48
35,7	48	48	48	48	48	48	48	48	48	48

⚖️(t) / 📏2,45 m - JM 850 - 🚛 - C25										
ΔVAL (m)	30	35	40	45	50	55	60	65	70	75
95,7	204									
94	192	192	192	180	192	192				
92,3	180	180	180	180	180	180	180	180		
90,7	168	168	168	156	168	168	168	168	168	180
85,7	132	132	132	120	132	132	132	132	132	144
80,7	108	108	96	96	96	96	96	96	108	108
75,7	72	72	72	72	72	72	72	72	72	84
70,7	48	48	48	48	48	48	48	48	48	60
65,7	48	48	48	48	48	48	48	48	48	48
60,7	48	48	48	48	48	48	48	48	48	48
55,7	48	48	48	48	48	48	48	48	48	48
50,7	48	48	48	48	48	48	48	48	48	48
45,7	48	48	48	48	48	48	48	48	48	48
40,7	48	48	48	48	48	48	48	48	48	48
35,7	48	48	48	48	48	48	48	48	48	48

⚖️(t) / 📏2,45 m - ZX 6830 - 🚛 - C25										
ΔVAL (m)	30	35	40	45	50	55	60	65	70	75
67,5	171			161						
65,8	151	151	151	141	151	151	151			
64,2	141	141	141	131	141	141	141	151		
62,5	121	121	121	111	111	111	121	121	131	131
57,5	101	91	91	91	91	91	81	91	91	101
52,5	81	81	81	81	71	71	71	81	81	71
47,5	61	81	81	81	61	71	51	61	61	61
42,5	51	81	81	81	61	71	51	51	41	51
37,5	51	81	81	81	61	71	51	51	41	51

Courbes de charges / Lastkurven / Load curves / Curvas de cargas / Curve di carico / Curvas de carga / Кривые нагрузок



↕ (m)		22	27	30	32	35	37	40	42	45	47	50	52	55	57	60	62	65	67	70	72	75	m
↕	↕ 12 t	↕										↕											
↕	↕ 6 t	↕										↕											
75	3,1 → 24,9	12	11	9,8	9,1	8,2	7,6	6,8	6,3	6	6	5,5	5,2	4,9	4,6	4,3	4,1	3,9	3,7	3,5	3,4	3,2	t
	3,1 → 26,2	12	11,6	10,2	9,3	8,4	7,7	7	6,5	6	6	5,8	5,5	5,1	4,9	4,6	4,4	4,1	3,9	3,7	3,6	3,4	t P+
70	3,1 → 26,5	12	11,7	10,4	9,7	8,7	8,1	7,3	6,8	6,2	6	5,9	5,6	5,2	5	4,6	4,4	4,2	4	3,8	t		
	3,1 → 27,5	12	12	10,8	10	8,9	8,2	7,5	7	6,4	6	6	5,9	5,5	5,2	4,9	4,7	4,4	4,2	4	t	P+	
65	3,1 → 28,3	12	12	11,2	10,4	9,3	8,6	7,8	7,2	6,6	6,2	6	5,9	5,5	5,2	4,9	4,7	4,5	t				
	3,1 → 29	12	12	11,5	10,5	9,4	8,7	7,9	7,4	6,8	6,4	6	6	5,8	5,5	5,1	4,9	4,7	t	P+			
60	3,1 → 29	12	12	11,6	10,7	9,7	9,1	8,3	7,8	7,2	6,9	6,4	6,1	6	5,9	5,6	t						
	3,1 → 29,5	12	12	11,8	10,9	9,9	9,3	8,4	8	7,4	7	6,5	6,2	6	6	5,7	t	P+					
55	3,1 → 30,4	12	12	12	11,3	10,3	9,7	8,8	8,4	7,7	7,4	6,8	6,5	6,1	t								
	3,1 → 33	12	12	12	11,1	10,3	9,4	8,8	8,1	7,6	7,1	6,7	6,3	t	P+								
50	3,1 → 30,4	12	12	12	11,4	10,3	9,7	8,9	8,4	7,7	7,4	6,9	t										
	3,1 → 31,9	12	12	12	11,9	10,8	10,2	9,3	8,8	8,1	7,7	7,1	t	P+									
45	3,1 → 31,8	12	12	12	11,9	10,8	10,1	9,3	8,8	8,1	t												
	3,1 → 34,7	12	12	12	12	11,9	11,2	10,2	9,7	9	t	P+											
40	3,1 → 31,2	12	12	12	11,7	10,5	9,9	9	t														
	3,1 → 34	12	12	12	12	11,6	10,9	10	t	P+													
35	3,1 → 31,5	12	12	12	11,8	10,6	t																
	3,1 → 34,3	12	12	12	12	11,7	t	P+															
30	3,1 → 29,9	12	12	11,9	t																		
	3,1 → 29,9	12	12	11,9	t	P+																	

↕ = ↕ - 0,67 t max.



↕ (m)		22	27	30	32	35	37	40	42	45	47	50	52	55	57	60	62	65	67	70	72	75	m
↕	↕ 12 t	↕										↕											
↕	↕ 6 t	↕										↕											
75	2,4 → 25	12	11,1	9,9	9,2	8,2	7,6	6,9	6,4	6	5,6	5,1	4,8	4,4	4,2	3,9	3,7	3,4	3,3	3,1	2,95	2,8	t
	2,4 → 26,3	12	11,7	10,3	9,4	8,4	7,8	7	6,6	6	5,8	5,4	5,1	4,7	4,5	4,1	3,9	3,7	3,5	3,3	3,2	3	t P+
70	2,4 → 26,5	12	11,8	10,5	9,7	8,8	8,2	7,4	6,9	6,3	6	5,5	5,2	4,8	4,5	4,2	4	3,8	3,6	3,4	t		
	2,4 → 27,5	12	12	10,9	10	9	8,3	7,5	7	6,4	6	5,7	5,5	5,1	4,8	4,5	4,3	4	3,8	3,6	t	P+	
65	2,4 → 28,4	12	12	11,3	10,5	9,4	8,7	7,8	7,3	6,7	6,3	5,9	5,6	5,1	4,9	4,6	4,4	4,1	t				
	2,4 → 29,1	12	12	11,5	10,5	9,4	8,7	7,9	7,4	6,8	6,4	6	5,8	5,4	5,1	4,8	4,6	4,3	t	P+			
60	2,4 → 29,2	12	12	11,6	10,8	9,8	9,1	8,4	7,9	7,3	6,9	6,4	6,1	5,9	5,6	5,3	t						
	2,4 → 29,6	12	12	11,8	11	9,9	9,3	8,5	8	7,4	7	6,5	6,2	6	5,7	5,4	t	P+					
55	2,4 → 30,5	12	12	12	11,4	10,3	9,7	8,9	8,4	7,8	7,4	6,9	6,6	6,2	t								
	2,4 → 33,1	12	12	12	12	11,2	10,4	9,5	8,9	8,1	7,7	7,1	6,8	6,4	t	P+							
50	2,4 → 30,6	12	12	12	11,4	10,3	9,7	8,9	8,4	7,8	7,4	6,9	t										
	2,4 → 32,1	12	12	12	12	10,9	10,2	9,3	8,8	8,1	7,7	7,2	t	P+									
45	2,4 → 32	12	12	12	12	10,8	10,2	9,4	8,9	8,2	t												
	2,4 → 34,8	12	12	12	12	11,9	11,2	10,3	9,7	9	t	P+											
40	2,4 → 31,4	12	12	12	11,7	10,6	10	9,1	t														
	2,4 → 34,1	12	12	12	12	11,7	10,9	10	t	P+													
35	2,4 → 31,6	12	12	12	11,8	10,7	t																
	2,4 → 34,4	12	12	12	12	11,8	t	P+															
30	2,4 → 30	12	12	12	t																		
	2,4 → 30	12	12	12	t	P+																	



↕ = ↕ - 0,19 t max.

Poids de flèche & lest de contre-flèche / Auslegergewicht & Gegenauslegerballast / Jib weight & counter-jib ballast / Peso de flecha y lastre de contra-flecha/Peso del braccio & zavorra di contro-braccio/Peso da lança & lastro da contra lança/Вес стрелы и балласт контр-стрелы

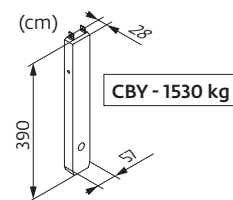
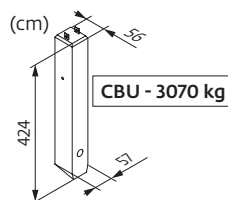
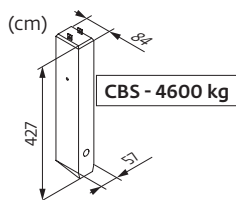









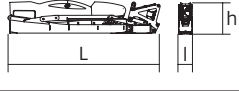

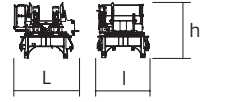
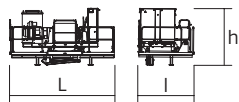
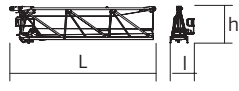
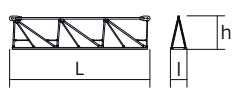

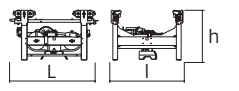
↕	↕ (kg) (+/- 5%)			↕		↕ (kg)	↕		
	↕	↕	↕	4600 kg	1530 kg		3070 kg	1530 kg	↕ (kg)
75 m	17830	17455	17890	5	2	26060	8	1	26090
70 m	17570	17210	17620	5	2	26060	8	1	26090
65 m	17180	16850	17235	5	2	26060	8	1	26090
60 m	16150	15850	16210	5	1	24530	8	0	24560
55 m	16150	15850	16210	5	1	24530	8	0	24560
50 m	15200	14900	15260	5	2	26060	8	1	26090
45 m	15050	14750	15110	5	2	26060	8	1	26090
40 m	14220	13920	14280	5	0	23000	7	1	23020
35 m	13610	13310	13670	4	2	21460	7	0	21490
30 m	12780	12480	12840	4	1	19930	6	1	19950

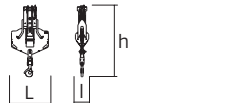

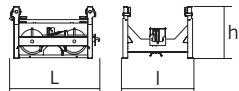

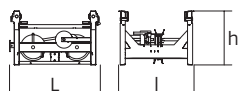

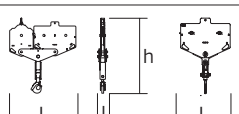

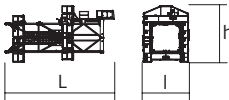

Encombremet et poids / Abmessungen und Gewicht / Dimensions and weight / Dimensiones y peso / Ingombro e peso  
 dimensões e pesos / габаритные размеры и вес

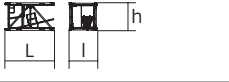
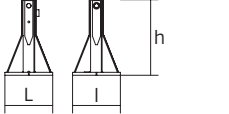
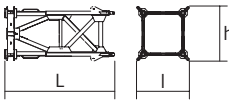
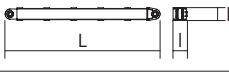
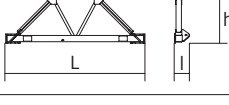
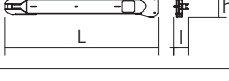
Partie tournante / Drehender Kranteil / Slewing crane part / Parte giratoria  
 Parte rotante / Parte rotativa / Поворотная часть :  75 m -  -  75 HPL™

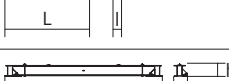

Partie tournante / Drehender Kranteil / Slewing crane part Parte giratoria / Parte rotante / Parte rotativa Поворотная часть		L (m)	l (m)	h (m)	kg (+/- 5%)	
Contre-flèche / Gegenausleger Counter-jib / Contra-flecha Controbraccio / Contra-lança Контр-стрела		12 12 12	1,25 1,25 1,25	2,5 2,5 2,5	1410 13600 11540	
Mât-cabine + cabine / Kabinenmast + Kabine Cab mast + cab / Mástil-cabina + cabina Portaralla superiore + cabina / Tramo-cabina + cabina Секция мачты кабины + кабина		5,03	2,22	2,49	6720	
Pivot / Krankopf Towerhead / Pivote Portaralla / Pivot Секция поворотной части		2 m 2,45 m	2,48 2,5	2,5 2,75	7620 8700	
Treuil de levage (+ câble) / Hubwerk (+ Seil) Hoisting winch (+ rope) / Mecanismo de elevación (+ cabo) Argano di sollevamento (+ fune) Guincho de elevação (+ cabo) Подъемная лебедка (+ канатом)		75 HPL™ 100 LVF	2,3 2,3	2,32 2,32	4500 4950	
Elément de flèche / Auslegerement Jib section / Elemento de flecha Elemento di braccio / Elemento de lança Секция стрелы		① 6 DVF	10,75	1,8	2,74	5500
Elément de flèche / Auslegerement Jib section / Elemento de flecha Elemento di braccio / Elemento de lança Секция стрелы		② ③ ⑤ ⑥ ⑦	10,21 10,31 10,22 10,24 10,19	1,2 1,2 1,2 1,2 1,2	2,5 2,42 2,39 2,1 1,83	3145 2420 1560 1235 950
Elément de flèche / Auslegerement Jib section / Elemento de flecha Elemento di braccio / Elemento de lança Секция стрелы		④ ⑧ ⑨	5,27 5,09 5,09	1,2 1,2 1,2	2,39 1,53 1,39	960 310 220
Chariot / Laufkatze Trolley / Carrello Carro / Carro-distribuidor Тележка			1,87	1,51	1,05	400
Moufle / Hubflasche Pulley block / Aparejo Bozzello / Cadernal Полиспаст			1,19	0,43	2,31	455
Chariot / Laufkatze Trolley / Carrello Carro / Carro-distribuidor Тележка			1,57	1,51	0,98	210
Chariot / Laufkatze Trolley / Carrello Carro / Carro-distribuidor тележка		 	1,7 1,86	1,51 1,51	1,03 0,98	245 236
Moufle / Hubflasche Pulley block / Aparejo Bozzello / Cadernal Полиспаст		 	1,65 1,09	0,22 0,27	1,78 1,62	450 265

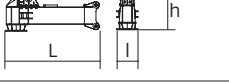
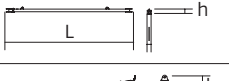
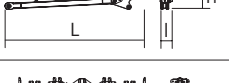
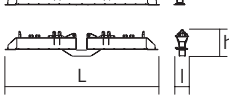
Рулоне / Kranturm / Crane tower Mástil / Torre / Torre Башня крана		L (m)	I (m)	h (m)	kg (+/- 5%)	
T 61 T 851		□ 2 m □ 2,45 m	10,83 11,18	4,14 4,84	4,47 5,8	9700 15750
K 649B KM 649E K 850/KR 849B KM 850.10B		□ 2 m □ 2 m □ 2,45 m □ 2,45 m	10,23 10,29 10,24 10,32	2,07 2,03 2,54 2,48	2,03 2,03 2,5 2,53	5290 4850 9470 10070
K 649A KMT 649A KR 649A KRMT 649A K 849A KR 849A KRMT 849A K 850/KR 849A KMT 850.10A		□ 2 m □ 2 m □ 2 m □ 2 m □ 2,45 m □ 2,45 m □ 2,45 m □ 2,45 m □ 2,45 m	5,23 5,23 5,23 5,23 5,23 5,23 5,23 5,24 5,32	2,07 2,07 2,1 2,1 2,53 2,53 2,55 2,54 2,54	2,03 2,03 2,08 2,08 2,5 2,5 2,53 2,5 2,51	2805 2570 3250 3050 3400 4290 4090 5575 5450
K 649C KRMT 649C KR 849C KRMT 849C		□ 2 m □ 2 m □ 2,45 m □ 2,45 m	3,57 3,57 3,57 3,57	2,07 2,1 2,55 2,55	2,03 2,08 2,53 2,53	1985 2450 3195 3205
Pieds de scellement / VerankerungsfüÙe Fixing angles / Pie de empotramiento Montante da anegare / Angulos fixadores анкера		P 62B P 800B P 850A	0,65 0,75 0,9	0,65 0,75 0,9	1,27 1,28 1,49	295 465 835
Mât-châssis / Grundmasteinheit Basic mast unit / Tramo-chasis Elemento base / Tramo-chassis Мачта для крепления к шасси		V 60A V 63A Y 800B	5,01 10,02 6,03	2,41 2,41 2,93	2,41 2,41 2,93	4390 7485 8620
Haubans / Mastabstütungen / Struts / Tornapuntas Puntoni / Escoras / Растяжка		V 60A V 63A Y 800B	4,51 4,51 5,51	0,29 0,33 0,5	0,29 0,33 0,45	420 515 1110
Sommier / Unterwagenhälfte Half-bearer / Testero Testata / Estrutura base Траверса		V 60A V 63A	6,7 6,7	0,7 0,7	2,31 2,31	1600 1850
1/2 Longeron / 1/2 Längsträger / 1/2 Side member / 1/2 Larguero 1/2 Longherone / 1/2 Longarina / 1/2 боковина		Y 800B	5,68	1,24	0,73	1520
Longeron / Längsträger / Side member / Larguero Longherone / Longarina / боковина		Y 800B	12	1,24	0,73	3050
Support lest / Ballastträger / Ballast support / Soporte de lastre Supporto zavorra / Suporte de lastro / Опора балласта		Y 800B	3,75	0,37	0,92	1085
Traverse de châssis / Unterwagentraverse / Chassis beam Traviesa chasis / Traversa carro / Travessa chassis / балка шасси		Y 800B	8,7	0,83	0,74	2240
Croix centrale (position transport) / Zentralkreuz (Transport- position) / Central cross (transport position) / Brazo central (posición transporte) / Croce centrale (posizione di trasporto) Braço central chassis (posição transporte) / крестообразное основание (транспортное положение)		YM 850 JM 850	5,2	1,7	1,5	6700
Mât-châssis / Grundmasteinheit Basic mast unit / Tramo-chasis Elemento base / Tramo-chassis Мачта для крепления к шасси		YM 850 JM 850	8,75	2,5	2,5	14600
Bras de châssis / Unterwagenträger / Chassis girder / Brazo de base en cruz / Traversa del carro / Braço de chassis / опорная балка шасси		YM 850 JM 850	3,8 5,2	0,9 0,9	1,55 1,55	2800 3200
Tirant de châssis / Unterwagenstreben / Chassis ties / Tirante de base en cruz / Tiranti del carro / Tirante de chassis / тяга крепления шасси		YM 850 JM 850	7,2	0,25	0,35	250
Haubans / Mastabstütungen / Struts / Tornapuntas Puntoni / Escoras / Растяжка		YM 850 JM 850	7,5 8,2	0,75 0,75	1,3 1,3	2100 2300
Bras de croix / Fundamentkreuzträger Cross girder / Brazo en cruz / Braccio croce / Braço da cruz Поперечная балка		ZX 6830	9,1 9,1	1,12 0,76	1,1 1,48	5265 5445

Mécanismes / Triebwerke / Mechanisms / Mecanismos / Meccanismi  
 Mecanismos / Механизмы

400 V - 50 Hz													ch - PS	kW	
	75 HPL™ 30	m/min	44	57	81	137	220	23	30	43	77	110	75	55	845 m
		t	6	4,5	3	1,5	0,2	12	9	6	3	1			
	100 LVF 30 Optima	m/min	61,5	79	105,5	136,5	162,5	32	41,5	55	71,5	81,5	100	75	941 m
		t	6	4,5	3	1,5	0,72	12	9	6	3	2,3			
	6 DVF 6 Optima	m/min	0 → 42 (12 t) 0 → 84 (8 t) 0 → 100 (4 t)										5,5	4	
	RVF 172 Optima+	tr/min U/min rpm	0 → 0,8										2 x 10	2 x 7,5	

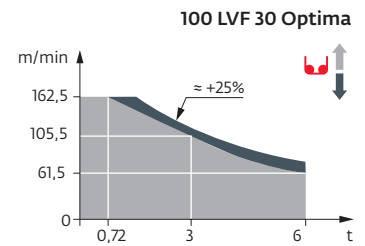

	IEC 60204-32		kVA	
	400 V (+10% -10%) 50 Hz		75 HPL™ : 84 → 54 kVA 100 LVF : 104 → 64 kVA	

	FR	DE	EN	ES	IT	PT	RU
	Profil de vent suivant EN 14439 C25-D25	Windbedingungen gemäss EN 14439 C25-D25	Wind conditions according to EN 14439 C25-D25	Conformidad de los condiciones de viento EN 14439 C25-D25	Condizioni del vento secondo EN 14439 C25-D25	Perfil de vento conforme EN 14439 C25-D25	Ветровой режим в соответствии с EN 14439 C25-D25
	Appel de flèche	Auslegerüberhöhung	Jib elevation	Elevación de la flecha	Inclinazione braccio	Desvio da lança	подъем стрелы
	Équipements standards	Standardausrüstungen	Standard equipment	Equipamiento de serie	Equipaggiamento standard	Equipamento de série	Стандартное оборудование
	Équipements optionnels	Sonderausrüstungen	Options	Equipamiento opcional	Equipaggiamento in opzione	Equipamento opcional	Дополнительное оборудование (опция)
	Fonction Potain Plus : Courbes de charges Plus	Funktion Potain Plus: Plus-Lastkurven	Potain Plus function: Plus load curves	Función Potain Plus: Diagrama de cargas Plus	Funzione Potain Plus: Curve di carico Plus	Função Potain Plus: Diagrama de cargas Plus	Функция контроля мощности Potain Plus: Диаграммы грузоподъемности Plus
	Hauteurs sous crochet associées aux courbes de charges Plus	Hakenhöhen mit Plus-Lastkurven	Hook heights with Plus load curves	Altura bajo gancho, usando el diagrama de cargas Plus	Altezze sotto gancio con curve di carico Plus	Altura livre, utilizando o diagrama de cargas Plus	Высота под крюком для диаграмм грузоподъемности Plus
	Réactions en service	Reaktionskräfte in Betrieb	Reactions in service	Reacciones en servicio	Reazioni in servizio	Reações em serviço	Реакция при работе
	Réactions hors service	Reaktionskräfte außer Betrieb	Reactions out of service	Reacciones fuera de servicio	Reazioni fuori servizio	Reações fora de serviço	Реакция в покое
	Poids total du lest	Ballast-Gesamtgewicht	Total ballast weight	Peso total del lastre	Peso totale della zavorra	Peso total do lastro	Общий вес балласта
	Cadre d'ancrage serré	Fester Verankerungsrahmen	Tightened anchorage frame	Marco de anclaje de apriete	Quadro di ancoraggio stretto	Quadro de amarração apertado	Прикрепленная анкерная рама
	Cadre d'ancrage desserré	Looser Verankerungsrahmen	Loosened anchorage frame	Marco de anclaje de desapriete	Quadro di ancoraggio allentato	Quadro de amarração solto	Отсоединенная анкерная рама
	Poids de flèche	Auslegergewicht	Jib weight	Peso de flecha	Peso del braccio	Peso da lança	вес стрелы
	Camion 13,4 m	Lkw 13,4 m	Lorry 13,4 m	Camión 13,4 m	Camion 13,4 m	Camião 13,4 m	Ррузовой автомобиль 13,4 м
	Conteneur High Cube 40', et/ou Flat Rack 20'	Container High Cube 40', und/oder Flat Rack 20'	Container High Cube 40', and/or Flat Rack 20'	Contenedor High Cube 40', y/o Flat Rack 20'	Container High Cube 40', e/o Flat Rack 20'	Contentor High Cube 40', e/ou Flat Rack 20'	40-футовый контейнер повышенной вместимости High Cube, и/или 20-футовая открытая платформа Flat Rack
	Levage	Heben	Hoisting	Elevación	Sollevamento	Elevação	Подъем
	Distribution	Katzfahren	Trolleying	Distribución	Ditribuzione	Distribuição	Перемещение по стреле
	Orientation	Schwenken	Slewing	Orientación	Rotazione	Rotação	Поворот
	Traslation	Kranfahren	Travelling	Traslación	Traslazione	Translação	Перемещение крана
	Puissance requise	Erforderliche Leistung	Required power	Potencia Necesaria	Potenza richiesta	Potência Necessária	Потребляемая мощность
	Fonction Power Control : vitesses treuils adaptés à la puissance disponible	Funktion Power Control: Geschwindigkeiten der Triebwerke werden an die verfügbare Leistung angepasst	Power Control Function: winch speeds adapted to the available power	Función Power Control: marchas de los cabrestantes adaptadas a la potencia disponible	Funzione Power Control: velocità degli argani adattate alla potenza disponibile	Função Power Control: velocidades de guincho adaptadas à potência disponível	Функция контроля мощности Power Control: регулировка скорости лебедок в зависимости от доступной мощности
	Nous consulter	Auf Anfrage	Consult us	Consultarnos	Consultateci	Consultar-nos	Проконсультируйтесь у нас
	Document commercial non contractuel. Pour toute information technique se référer à la notice correspondante.	Unverbindliches Vertriebsdokument. Für technische Informationen, siehe die entsprechenden Anweisungen.	This commercial document is not legally binding. For any technical information, please refer to the corresponding instructions.	Documento comercial no contractual. Para cualquier información técnica, ver la noticia correspondiente.	Documento commerciale non vincolante, per tutte le informazioni tecniche fare riferimento al catalogo istruzioni.	Documento comercial não contratual. Para qualquer informação técnica complementar consultar as respectivas instruções.	Этот коммерческий документ не является юридически обязательным. Для получения технической информации, см. соответствующие инструкции.

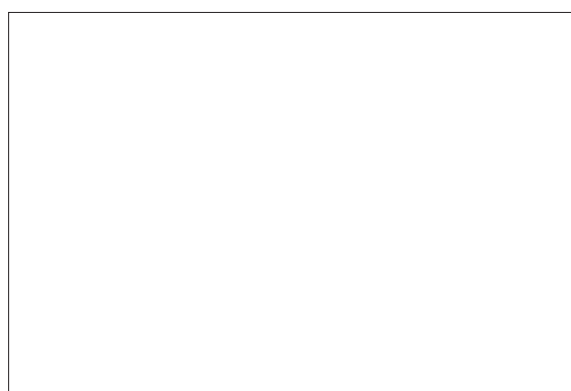

© 2018 The Manitowoc Company, Inc. www.manitowoc.com